



# HORIZONTAL BOTTLE COOLERS



SPC: 870874 APN: 6344774

SPC	APN	SPC	APN
870874	6344774	870875	7344773
870876	8344772	871891	3497609
107138	0417071	107191	0417535
021585	0089870	021595	0089961
021603	0090019	871900	9380726

## SPECIFICATIONS/FEATURES

### Construction

- Exterior: Durable, 10 mil thick, black laminated vinyl that will not peel or chip, or optional stainless steel.
- Heavy gauge stainless steel countertop and lids.
- Interior: Long lasting, heavy duty rust-resistant galvanized steel.
- All models are 26<sup>1</sup>/<sub>2</sub>" deep.
- Entire cabinet structure and doors are insulated using foamed-in-place CFC free high density, polyurethane foam.
- Floor drain provided, drains to condensate pan.
- Heavy duty, 10 mil thick pure grade white vinyl coated wire dividers.
- Versatile top slides easily under the bar top, or can be used as a counter storage space for glasses or bar supplies.

### Doors

- Easy glide insulated stainless steel lid.

### Application

- Performs in the hottest, most humid climates.
- Excellent for all tropical beach bars.

### Models Available

- 36<sup>3</sup>/<sub>4</sub>", 50", 65", and 95" Models in black or stainless steel.
- Huge capacity requires minimum floor space.

### Refrigeration System

- Refrigeration system factory balanced using environmentally friendly CFC-free R134a refrigerant.
- Factory pre-engineered capillary tube system with oversized condenser and evaporator to reduce product pull down time and to consistently maintain 32° to 38°F interior cabinet temperature (non-adjustable capillary tube system superior to problematic expansion valve).
- Forced air refrigeration system for maximum performance.
- Evaporator is epoxy coated at the time of manufacture to eliminate the potential of corrosion.
- Air vents on front and right sides to maximize the flow of fresh air through the condenser.
- Self-contained refrigeration system.
- Slide out condensing unit can be accessed and easily serviced by a single repairperson.

### Installation

- Simple plug in installation.
- No plumbing or condensate heater required.

### Electrical Characteristics

- Unit completely pre-wired at factory, and ready for final connection to a 120/60/1 phase -15 amp dedicated outlet. 7' Cord and plug set is provided. NEMA 5-15P.

### Warranty (USA)

- 1 Year parts and labor warranty.
- 5 Years compressor warranty.

Specifications subject to change without notice



**SUPERIOR WARRANTY**  
1 YEAR LABOR  
1 YEAR PARTS  
5 YEAR  
COMPRESSOR

Superior  
REFRIGERATION  
Products are  
Certified to  
NSF Standard

**7**



Made in the U.S.A.



SPC: 870875 APN: 7344773



SPC: 021603 APN: 0090019



# HORIZONTAL BOTTLE COOLERS

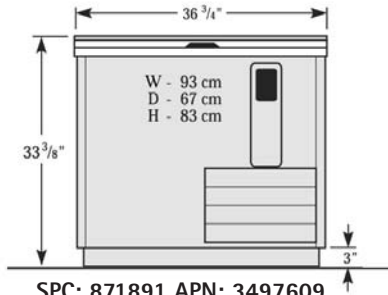

SPC: 871891 APN: 3497609  
SPC: 021585 APN: 0089870  
Front View

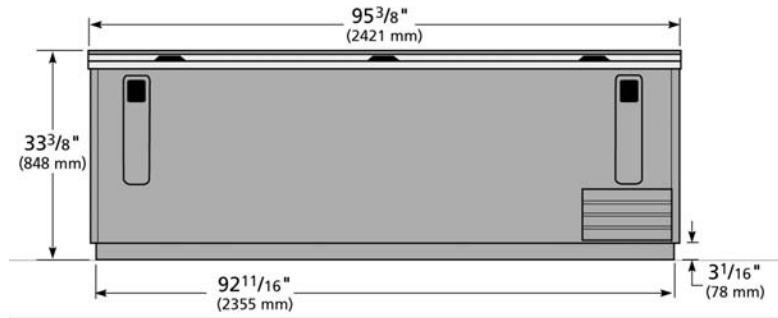

SPC: 870876 APN: 8344772  
SPC: 871900 APN: 9380726  
Front View

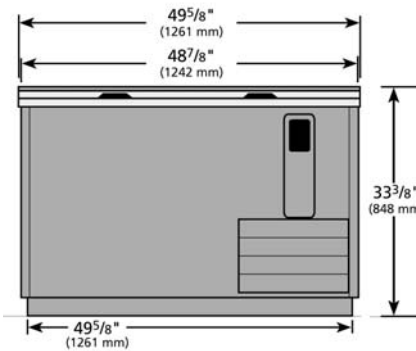

SPC: 870874 APN: 6344774  
SPC: 021595 APN: 0089961  
Front View

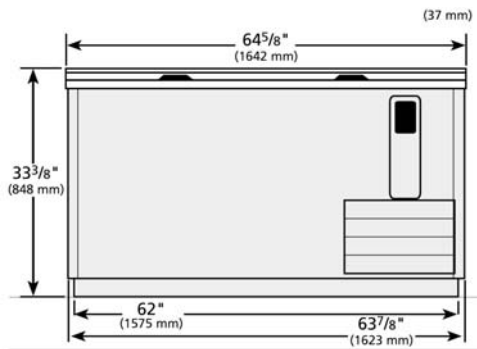

SPC: 870875 APN: 7344773  
SPC: 021603 APN: 0090019  
Front View

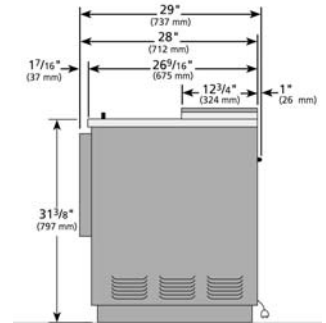

Common Side View

## ROUGH-IN DATA

SPC	APN	Lids/ Drawer	Compartments	Capacity (12 oz. btls./12 oz. cans)	Dimensions			H.P.	Volts	Phase	Amps	NEMA Config.	Cord Length	Crated Weight
					W	D	H							
871891 (B)	3497609	1	3	11 cases/14 1/2 cases	36 3/4"	x 26 5/8"	x 33 3/8"	1/5	120	1	4.6	5-15	7'	205 lbs.
870874 (B)	6344774	2	4	16 1/2 cases/24 cases	49 5/8"	x 26 5/8"	x 33 3/8"	1/3	120	1	8.1	5-15	7'	245 lbs.
870875 (B)	7344773	2	5	22 cases/32 1/2 cases	64 5/8"	x 26 5/8"	x 33 3/8"	1/3	120	1	7.3	5-15	7'	290 lbs.
107138 (B)	0417071	3	6	30 cases/42 cases	80 1/2"	x 26 5/8"	x 33 3/8"	1/3	120	1	8.7	5-15	7'	365 lbs.
870876 (B)	8344772	3	8	37 1/2 cases/55 cases	95 3/8"	x 26 5/8"	x 33 3/8"	1/2	120	1	9.2	5-15	7'	465 lbs.
021585 (S)	0089870	1	3	11 cases/14 1/2 cases	36 3/4"	x 26 5/8"	x 33 3/8"	1/5	120	1	4.6	5-15	7'	205 lbs.
021595 (S)	0089961	2	4	16 1/2 cases/24 cases	49 5/8"	x 26 5/8"	x 33 3/8"	1/3	120	1	8.1	5-15	7'	245 lbs.
021603 (S)	0090019	2	5	22 cases/32 1/2 cases	64 5/8"	x 26 5/8"	x 33 3/8"	1/3	120	1	7.3	5-15	7'	290 lbs.
107191 (S)	0417535	3	6	30 cases/42 cases	80 1/2"	x 26 5/8"	x 33 3/8"	1/3	120	1	8.7	5-15	7'	365 lbs.
871900 (S)	9380726	3	8	37 1/2 cases/55 cases	95 3/8"	x 26 5/8"	x 33 3/8"	1/2	120	1	9.2	5-15	7'	465 lbs.

B - Black exterior, S Stainless exterior. Clearance required for coolers: sides - 2"/50mm, top - N/A, rear 2"/50mm. Standard bottles, not long bottles. Add 1 5/8" to depth for cap catcher. Easy to install. No plumbing connection. Equipped with 7' cord and plug set behind compressor. Made exclusively for Next Day Gourmet® by True Mfg.

## OPTIONAL ACCESSORIES

### Casters

- SPC: 054915 APN: 0231530 - Set of four 3" casters with frame, 2 locking, for 36 3/4" models
- SPC: 801275 APN: 7105182 - Set of four 3" casters with frame, 2 locking, for 50", 65" and 80" models
- SPC: 801276 APN: 7344740 - Set of six 3" casters with frame, 3 locking, for 95" models
- 2 1/2" Caster sets also available.

### Dividers

- T-872209 - Center divider for 36 3/4" models
- T-872208 - Regular divider for 36 3/4" models
- T-872204 - Center divider for 50", 65", and 95" models
- T-872203 - Regular divider for 50", 65", and 95" models

- SPC: 706459 APN: 9508235 - Stainless steel cleaner.

Lock lids available for all models.

## ALSO AVAILABLE

- 24 3/4" Black bottle cooler