



ELECTRIC 10 LB. COUNTER FRYER

SPC
870851

APN
8349441



SPC: 870851
APN: 8349441



NEMA 5-15P

SPECIFICATIONS/FEATURES

Construction

- Construction features include an easy clean, stainless steel body.
- 10 Lb. stainless steel, lift-out nickel plated kettle for easy cleaning.
- On-off switch for exact control.
- Adjustable 2 1/2" legs for leveling with other equipment.
- 2-Side mounted 3 1/2"W x 4 5/8"D x 8 1/2"L nickel plated baskets.

Elements

- Tubular, 2 position, swing-up element for easy access.
- Adjustable snap action thermostat for instant response to temperature change.
- Hi-limit safety thermostat for safety control.
- Preheats to 350°F in only 9 minutes.

Application

- Produces up to 10 lbs. of fries per hour (raw to finish).
- For performance, value and versatility in recreational facilities, restaurants. Superior's electric countertop 10 lb. fryers are what you're looking for to complete your product requirements.
- This high performance countertop fryer is compact enough for all locations and can be plugged into any standard 120 volt outlet.

Electrical Information

- These fryers operate on 120V supplied with a 6ft. cord and NEMA 5-15P plug.
- 120V, 1800 watts, 15 amps, 1 phase.

Specifications

Electric fryer has an all stainless steel body. A 200° - 375°F (93° - 191°C) adjustable thermostat and a hi-limit safety thermostat are provided. A separate on-off switch is standard. One-piece stainless steel lift-out 10 lb. (4.5kg) capacity kettle is provided. Unit has a tubular, two position, swing-up element with a rated wattage of 1800 watts on 120 volts. Two side mounted nickel plated baskets are provided as standard. 6 Ft. (182.9cm) lead-in cord and plug - NEMA #5-15P, 120V, 15A is standard. Unit carries approval of Underwriters Laboratories (UL), cUL, and National Sanitation Foundation (NSF).

Warranty (USA)

- 1 Year parts and labor warranty.

SUPERIOR WARRANTY
1 YEAR LABOR
1 YEAR PARTS

Superior
COOKING
Products are
Certified to
NSF Standard

4



Made in the U.S.A.

Specifications subject to change without notice.



ELECTRIC 10 LB. COUNTER FRYER

SPC: 870851
APN: 8349441

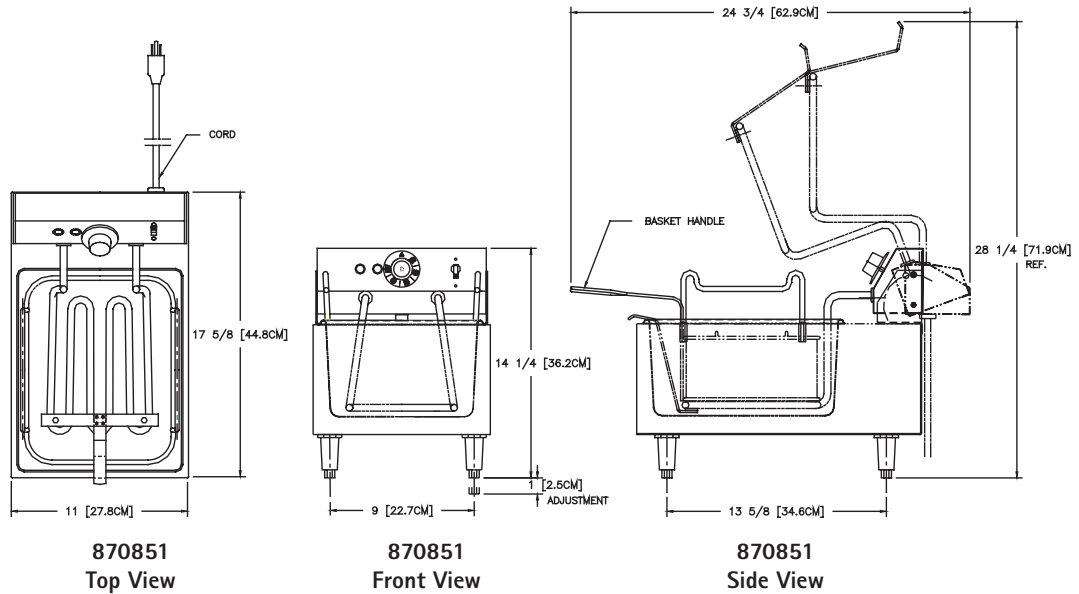

ROUGH-IN DATA

SPC	APN	Dimensions W x D x H	Volts	Watts	Nominal Amps	Cooking Surface	Fat Container W x D x H	NEMA Config.	Cord Length	Installed Weight	Crated Weight
870851	8349441	11" x 18" x 14"	120	1800	15	10"	9" x 11" x 6"	5-15	6'	20 lbs.	25 lbs.

Legs adjustable from 2 1/2" to 3 1/2"
6' Cord and NEMA 5-15P plug provided.

Made exclusively for Next Day Gourmet® by Star Mfg.

PERFORMANCE DATA

SPC	APN	Pre-Heat to 375° F (177°C)	Fat Capacity	Pounds of Raw to Finish French Fries Per Hour	Watts Per Hour to Maintain 350° F (177°C)
870851	8349441	9 Minutes	10 lbs. (4.5kg)	10 lbs. (11.3kg)	450

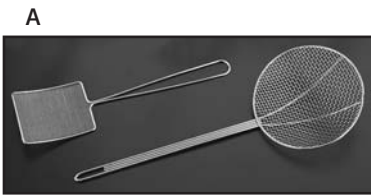

B



C



803481

D



800219



E

OPTIONAL ACCESSORIES

Wire Mesh Skimmers

A versatile reinforced skimmer of all welded construction. Wire Mesh has 3 openings to an inch. Retinned, heavily plated.

- A. SPC: 808063 SPC: 7329451 5" x 6", Fine mesh 20" O.A. length
- B. SPC: 805909 APN: 5329776 Round, 7" dia. mesh 20" O.A. length
- ❑ SPC: 805918 APN: 1329788 Round 9" dia. mesh 24" O.A. length

C. Fryer Cleaner

Dissolves fat and grease quickly and easily. Prolongs shortening life.

- ❑ SPC: 703904 APN: 6348890 Fryer cleaner

D. Fry Scoops

- ❑ SPC: 803481 APN: 5009048 Aluminum french fry scoop, right handed
- ❑ SPC: 800219 APN: 4348967 Polysulfane bagging scoop, right handed

E. Star Heat Lamp

Keeps foods piping hot for serving! Use for fish, fries, chicken, shrimp, and other fried foods. Great for pastries too. Adjustable height 20" to 29". 14"W x 20"L. 120V, 60 cycle, two 250 watts white bulbs included.

- ❑ SPC: 834387 APN: 1348523 Heat lamp

ALSO AVAILABLE

- ❑ Heat lamps
- ❑ Speciality fryer baskets
- ❑ Floor model fryers
- ❑ Gas fryers
- ❑ Filtration systems
- ❑ Equipment stand