



# ELECTRIC 30 LB. TWIN POT COUNTER FRYER

**SPC**  
870853

**APN**  
1349455



**SPC: 870853**  
**APN: 1349455**



**Made in the U.S.A.**



## SPECIFICATIONS/FEATURES

### Construction

- Superior's Electric Twin Pot Fryer features all stainless steel construction with two separate housings provided.
- Separate kettles with individual controls conserve energy during non-peak periods.
- Immersion type tubular heating elements provide excellent frying performance.
- Removable 15lb. nickel plated steel kettles make cleaning fast and easy.
- Snap-action thermostat provides accurate temperature control from 200° to 375°F (93° to 191°C).
- Heavy duty on-off switches and indicating lights provide easy operations.
- Basket size: 8<sup>3</sup>/<sub>4</sub>" x 10"L.
- Knob guards protect switches.
- Nickel plated die cast legs. Adjustable from 4" to 5<sup>3</sup>/<sub>8</sub>" (10.2cm to 13.7cm)

### Applications

- Produces up to 50 lbs. of fries from raw to finished. Superior's Twin Pot Fryer offers great frying flexibility. No matter what the menu; onion rings, fries, chicken or fish; this twin pot fryer keeps food flavors where they belong.
- Separate controls allow for a variety of uses and conserves energy during off-peak.

### Electrical

- This fryer operates on either 208 or 240 volts at up to 9.2kW.
- A terminal block for making line connections is provided.
- No cord or plug is provided as this unit requires hard wiring by a qualified installer.

### Specifications

Electric fryer is constructed with an all stainless steel body. Two separate control housings are provided. Each housing has indicating lights, adjustable snap-action thermostat, hi-limit safety thermostat and an immersion type tubular element. Housing swings up to allow the 15 lb. (6.8kg) fat capacity nickel plated steel kettle to be removed. Two heavy duty on-off pole switches. Two side mounted 8<sup>1</sup>/<sub>2</sub>" (21.6cm) x 10" (25.4cm) nickel plated, perforated steel mesh baskets are provided as standard. 4"H (10.2cm) nickel plated die cast legs. A terminal block for making line connections is provided. Units are UL listed, NSF approved and CSA listed. No cord or plug is provided as this unit requires hard wiring by a qualified installer.

### Warranty (USA)

- 1 Year parts and labor warranty
- For commercial use only, not warranted for home use.

Specifications subject to change without notice



# ELECTRIC 30 LB. TWIN POT COUNTER FRYER

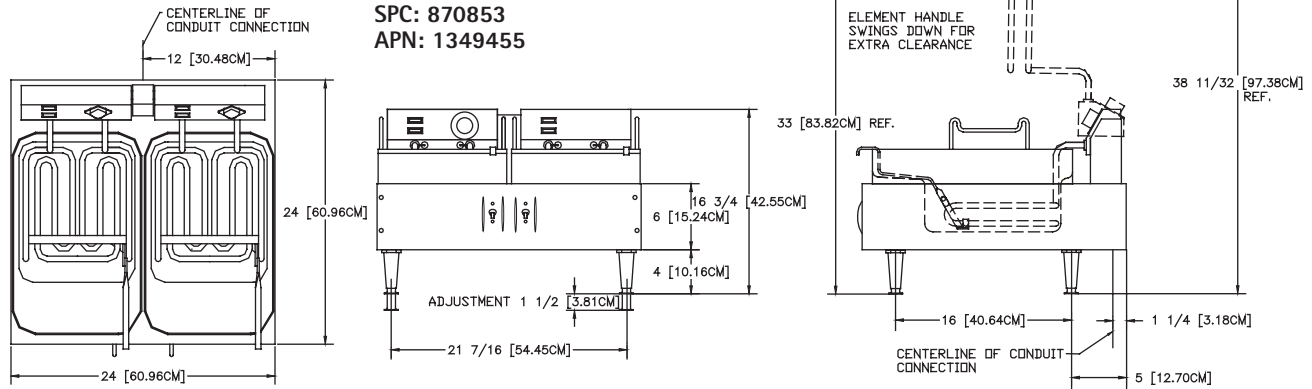

## ROUGH-IN DATA

SPC	APN	W x D x H	Volts	Normal Wattage	Cooking Amps	Fat Container Surface	Foam Compartment W x D x H	Installed W x D x H	Crated Weight	Installed Weight
870853	1349455	24" x 24" x 16 3/4"	208	6910	33.2	10"	10 1/2" x 12 1/2" x 4 3/4"	11 1/2" x 18" x 2 3/4"	69 lbs.	79 lbs.
		24" x 24" x 16 3/4"	240	9200	38.3	10"	10 1/2" x 12 1/2" x 4 3/4"	11 1/2" x 18" x 2 3/4"	69 lbs.	81 lbs.

Note: Cord and plug not provided. Made exclusively for Next Day Gourmet® by Star Mfg.

## PERFORMANCE DATA

SPC	APN	Pre-Heat to 350°	Fat Capacity	Pounds of Raw to Finish French Fries	Watts Per Hour to Maintain 350°
870853	1349455	6 1/2 Minutes	30 lbs. (13.6kg)	50 lbs. (22.7)	430

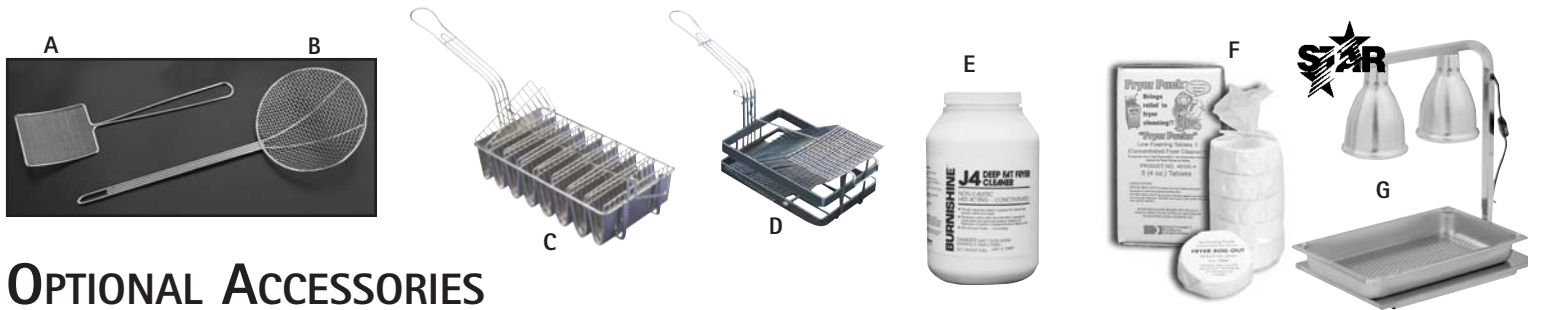

## OPTIONAL ACCESSORIES

- SPC: 803481 APN: 5009048** Aluminum french fry scoop, right handed
- SPC: 800219 APN: 4348967** Polysulfane bagging scoop, right handed

### Wire Mesh Skimmers

A versatile reinforced skimmer of all welded construction. Wire Mesh has 3 openings to an inch. Retinned, heavily plated.

- A. SPC: 808063 SPC: 7329451** 5" x 6", Fine Mesh 20" O.A. length
- B. SPC: 805909 APN: 5329776** Round, 7" dia. Mesh 20" O.A. length
- SPC: 805918 APN: 1329788** Round 9" dia. Mesh 24" O.A. length

### Taco and Tostada Making Accessories

- C. SPC: 049292 APN: 0218909** Large Capacity Taco Shell Basket. Designed to fry 6" tortillas, up to eight at a time. Nickel and chrome finish. 6 1/2"W x 3 1/4"D x 12"L. 4 lbs.
- D. SPC: 049298 APN: 0218958** Tostada Basket. Fries 6" corn tortillas into a crisp, flat shape. Frying capacity/load: 1 to 18 tortillas. Nickel and chrome finish. 6 1/4"W x 5"D x 10 1/2"L. 4 lbs.

### E. Fryer Cleaner

- Dissolves fat and grease quickly and easily. Prolongs shortening life.
- SPC: 703904 APN: 6348890** Fryer Cleaner

### F. Fryer Pucks

Concentrated, low foaming tablets designed for fryer cleaning. Heavy duty high alkaline detergent formulated to meet the toughest cleaning jobs.

- SPC: 704951 APN: 7366446** Fryer pucks cleaner, box of 30

### G. Star Heat Lamp

Keeps foods piping hot for serving! Use for fish, fries, chicken, shrimp, and other fried foods. Great for pastries too. Adjustable height. 20" to 29". 14"W x 20"L. 120V, 60 cycle, two 250 watts white bulbs included.

- SPC: 834387 APN: 1348523** Heat Lamp

## ALSO AVAILABLE

- Timers
- Filtration systems
- Equipment stands with casters
- Heat lamps
- Floor model fryers
- Gas fryers