



CONVECTION OVEN

GAS, SINGLE DECK



(shown with optional casters)

Models:

SPC	APN	Description
871709	6465090	Natural Gas
048680	0213850	Propane Gas

Superior offers a series of convection ovens that deliver increased productivity in a smaller footprint. It features the JS-901 Jet Stream Burner System. Horizontal, 5 1/2" burners are cool-to-the-touch but actually produce a high efficiency flame. Energy saving 54,000 BTU models produce high quality, even baking that the top Chefs need and demand. Designed with dependent door allowing operator to open both doors simultaneously with only one handle.

STANDARD FEATURES

- 54,000 BTU
- Stainless steel front and top, sides are galvanized
- Single deck convection oven is 55" in height
- Dependent doors with window
- Porcelainized interior
- Large oven capacity to fit full size sheet pan or two 1/2 size.
- Rugged double door unit
- "Soft Air" two-speed, 1/2 hp fan motor
- 11-position rack guides
- 5 plated oven racks
- Electronic ignition
- Forced cool down fan mode
- Oven "ready" light - cycles with burners
- Solid state temperature controls
- 60 minute mechanical cook timer
- Stainless steel door seals

Special orifices required for over 2,000' elevation, use 048680 and specify elevation and gas.

CONTROLS:

SC -Standard Controls

140°F to 500°F solid state thermostat and 60 minute mechanical cool timer

Superior has a policy of continuous product research and improvement. We reserve the right to change specifications and product design without notice. Such revisions do not entitle the buyer to corresponding changes or improvements for previously purchased equipment.

OPTIONS

SPC	APN	Description
801846	3346038	3/4" x 48" quick disconnect and restraining device with flexible hose kit. Complies with ANSI Z 21.69
803135	9363474	Casters -all swivel, front with locks for model SPC 871709/ APN 6465090
028958	0142422	Casters -all swivel, front with locks for model SPC 048680/ APN 0213850

- Extra oven rack
- Down draft diverter for direct flue
- Stacking kit available

TECHNICAL DATA

Listed on reverse side.

WARRANTY

One year Parts and Labor Warranty

Made exclusively for Superior by Southbend.



SUPERIOR WARRANTY
1 YEAR LABOR
1 YEAR PARTS

Superior
COOKING
Products are
Certified to
NSF Standard

4



CONVECTION OVEN

GAS, SINGLE DECK

Models:

SPC	APN	Description
871709	6465090	Natural Gas
048680	0213850	Propane Gas

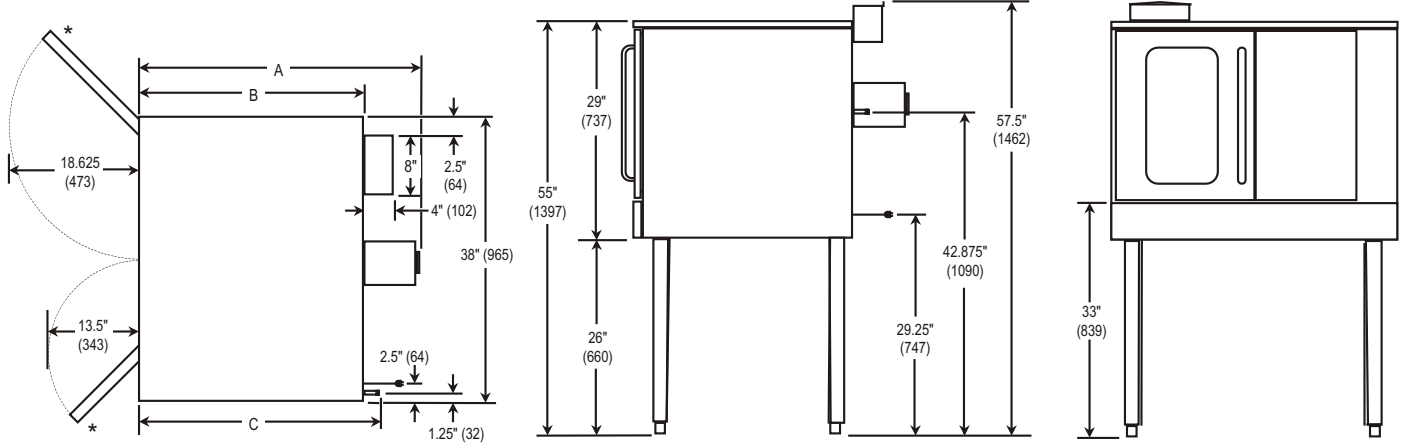

Dimensions-in(mm)

Models		Depth			Oven Interior			Rack Clearance		Shipping Crate				
SPC	APN	A	B	C	Width	Depth	Height	Width	Depth	Width	Depth	Height	Volume	Weight
871709	6465090	40.5"	30"	34.375"	29"	22.5"	20"	28.25"	22"	55"	45.5"	45"	65.17 cu. ft.	620 lbs.
048680	0213850	(1029)	(763)	(874)	(737)	(572)	(508)	(718)	(559)	(1399)	(1157)	(1144)	(1.85 cu. m.)	(281.23kg)

* Door handles add 3" to clearance

UTILITY INFORMATION

Gas: Standard depth 54,000 BTU
 One 3/4" male connection (for location, see drawing above.)
 Required supply pressure: Natural Gas 7" W.C. Propane 11" W.C.

Electric: Each deck with individual supply (for location, see drawing above.)

Standard: 120/60/1 – furnished with 6 ft. cord w/3 prong plug (1plug / deck). NEMA#5-15p. Total maximum amps 7.9

All units are shipped single phase.

CONSTRUCTION (BIDDING) SPECIFICATIONS:

Commercial Gas Convection Oven – 38 1/8" W x 38 3/4" D x 55" H (Including 26" legs.)

Exterior Finish: Stainless steel front and top. Galvanized sides and Aluminized steel back.

Doors: Dependent doors with window. Stainless steel construction -front and top; sides are galvanized. Heavy duty welded steel frame. 5/8" diameter pivot rod with hinge pins.

Oven Interior: Porcelain enamel finish

Rack and Rack Guides: Bright plated, heavy duty removable wire rack guides spaced on 1 5/8" centers offer 11 different rack positions. 5 brilliant plated heavy-duty wire racks provided with each oven.

Blower Fan and Motor: 1/2 hp. 2 speed motor, 1725/1140 r.p.m. motor mounted to right side.

Oven Heating: Inshot style burners direct flame towards rear of combustion chamber. Combustion products are drawn into oven interior and recirculated prior to venting.

Electronic Ignition: Hot surface igniter with flame safety device.

Control Panel: Located on front, at right side of oven, away from heat zone. Panel hinges down for easy servicing and is removable.

Leg Options: Round black standard

MISCELLANEOUS INFORMATION

If using flex hose connector, the I.D. should not be smaller than 3/4" and must be comply with ANSI Z 21.69

If casters are used with flex hose, a restraining device should be used to eliminate undue strain on the flex hose.

Clearances from combustibles: Top-0", bottom-0", right side-0", left-3".

Recommended install under vented hood.

Check local codes for fire and sanitary regulations.

If the unit is connected directly to the outside flue, an A.G.A. approved down draft diverter must be installed at the flue out let of the oven.

INTENDED FOR COMMERCIAL USE ONLY. NOT FOR HOUSEHOLD USE.